

QUANTUM RS75 PUMP-OUT PEDESTAL

ROLEC
Global *Marina* Services



The **QUANTUM RS75** PUMP-OUT Range

The Quantum RS75 includes built-in controls and has been designed to work in conjunction with a remote pump.

PRODUCT FEATURES

- 25 micron marine grade 6063 anodised extruded aluminium body
- High impact resistant UV stabilised polycarbonate lighting lens assembly
- Start/stop pump control
- Can operate with a variety of pump sizes and types
- Sewage and sea water resistant materials
- 360 degree low energy LED lighting
- 10m of 38mm ship-to-shore hose
- Valve operated euro-probe c/w optical viewing lens
- Built-in variable setting pump-out timer and electrical protection switchgear
- Front, back and side panel material variants: steel, composite, aluminium
- Front, back and side panel colour variants
- The range consists of free-to-use or pay-to-use options
- Pumping ability ranges from 100m to 1000m horizontal (Depending on the pump specified RS200/RS250/RS300)



10m
Hose



UV
Stabilised



CE
Certified



IP
Rated



LED
Illumination



IK10 Impact
Resistant

SPECIFICATIONS

CHARACTERISTICS

Materials	Head: FR-VS UV Stabilised Polycarbonate Body: Alloy 6063 BS EN 10204:2004, BS EN 573-3:2013, BS EN 755-2:2016
Panel Material Options	304/ 316 Stainless Steel Powder Coated Aluminium Composite
Dimensions	A: 1250mm B: 1440mm C: 360mm D: 382.5mm E: 175mm F: 260mm G: 262.5mm
Operating Temperature	-30°C to +60°C (Installed and Operated Within Multiple Climates from Around the Globe)
IP Rating	IP66 BS EN 60529
Impact Rating	IK10 BS EN 62262:2002
Compliances	BS7671 Wiring Regulations BS EN 61439-2:2011, BS EN 61439-5:2015 CE Certified Low Voltage Directive 2014/35/EU BS EN IEC 60947-1 / BS EN IEC 60947-3 Electromagnetic Directive 2014/30/EU UV Stabilised Flame Retardant to UL94 Flame Rating at V2
	
Typical Weight (AVG)	27kg

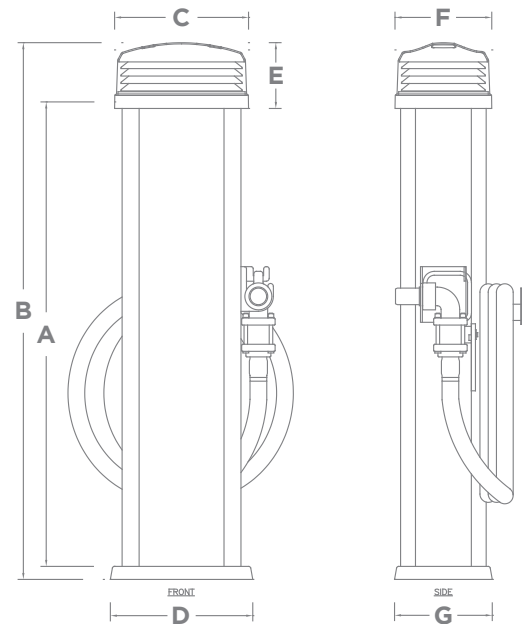

ELECTRICAL

Voltage	230V or 400V (1Ø or 3Ø)
Overload & Fault Current Protection	MCB/RCD or RCBO IEC 60898-1/IEC 61009-1/IEC 61009-1

PUMP

The spec of the pump required would depend on usage required, on the distance from the pump-out pedestals and how many pedestals are connected to the pump.

Pump Spec	Refer to the Data Sheets Below for Complete Pump Specs RS200 Pump: MSDS-0024 RS250 Pump: MSDS-0025 RS300 Pump: MSDS-0026
-----------	--

LIGHTING

Type	360 Degree Low Energy LED
Rating	4000k 10x1 Watt
Protection	6amp RCBO

OPTIONS

- Panel colours and materials
- Rinse tap
- Branding vinyls
- Payment facility
- Keyswitch control

Images are for marketing purposes only and are not contractual © 2019



Head office contact:
t: +44 (0) 1205 724754
f: +44 (0) 1205 724876
rolec@rolecserv.co.uk

Rolec Services Ltd
Ralphs Lane, Frampton West
Boston, Lincolnshire
UK. PE20 1QU

MSDS-0027

 @RolecMarina
www.rolecserv.com