



ROLEC

DIRECT CONNECTION UNITS



Designed
& Stocked
in the UK

Electrical solutions for caravan and holiday parks

DIRECT CONNECTION UNITS

Electrical solutions for caravan and holiday parks

Specifically designed to provide a 16A, 32A or 63A electrical supply via its direct connection facility to residential and holiday homes as well as static caravans.

Every unit is complete with an IP65 weatherproof polycarbonate enclosure, RCBO providing overload and 30mA fault current protection, which is accessible via a waterproof customer re-set flap, and built-in cable terminals.

MID compliant kWh metered units provide accurate billing information for park operators. Smartcard metered units allow visitors to pay upfront for their electricity consumption, encouraging them to be more energy conscious and reducing unnecessary electricity usage.



Product features

- Available in 16A, 32A & 63A versions
- 18th edition regulations compliant
- Optional MID compliant kWh & pre-paid smartcard metering
- Built-in overload and 30mA fault current protection
- IP65 weatherproof polycarbonate enclosure
- Built-in cable terminals
- Switchgear access flap
- Optional galvanised mounting post
- Easy to install & maintain
- IP Rated & UV stabilised
- Fire retardant
- Designed & stocked in the UK



Solutions for all locations

Ideal solution for residential and holiday homes as well as static caravans sites.



Efficient electrical output

Offers up to 63A power output capable of supplying increased demand for electrical amenities



Easy to install & maintain

Modular design with easy access to internal components allowing for maintenance and future upgrades.



Accurate billing

Optional built-in MID-approved energy metering ensures accurate consumption reading.



Significant cost savings

Smartcard metering options allow customers to pay upfront, reducing unnecessary electricity usage.



Strong, durable & compliant

IP rated, UV stabilised, fire retardant and compliant with 18th edition wiring regulations.

Specifications

Product Overview:

Metering Type	Power Output	Fault Protection	Product Code	Enclosure Size
1x 45A kWh meter	16A	16A 30mA RCBO	LSDC0110	Small
	32A	32A 30mA RCBO	LSDC0120	
1x 100A kWh meter	63A	C63A 1pole MCB, 63A 30mA RCD	LSDC0130	
63A Class 1 smartcard meter	16A	16A 30mA RCBO	LSDC0210	Large
	32A	32A 30mA RCBO	LSDC0220	
	63A	C63A 1pole MCB, 63A 30mA RCD	LSDC0230	

Specifications

Unit Dimensions:

Small Enclosure:

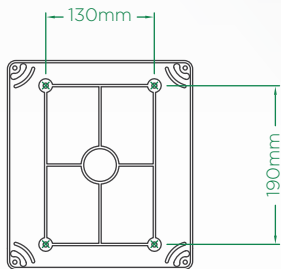
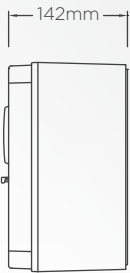
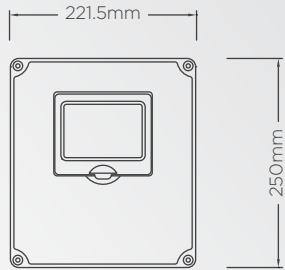

Fixing Points

Large Enclosure:

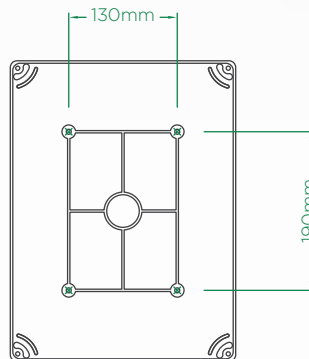
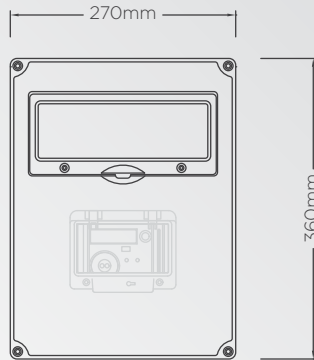

Fixing Points

Optional Mounting Post:

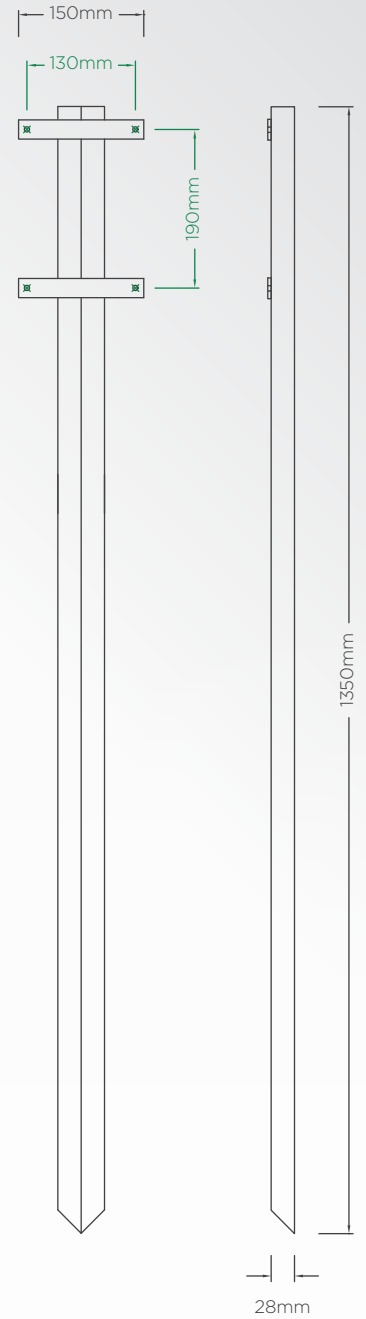

Specifications

Technical Data:

Built-in Protection	AC overload & fault current protection – 30mA Type A RCBO (per socket) (16A, 32A or 32A as appropriate)
Input Voltage	Single phase – 220 to 250V AC / 50Hz
Cable Terminals	Single Phase – 3x 50mm Tunnel terminals fitted as standard – 1P + N + E (other sizes available on request)
Earthing	Brass Earth plate & Earth terminals
Energy Metering	Integrated Class 1 MID compliant metering (model dependant)
Dimensions	Excluding sockets/connectors: <ul style="list-style-type: none"> • Small Enclosure – 221.5mm x 250mm x 142mm (W x H x D) • Large Enclosure – 270mm x 360mm x 152mm (W x H x D)
Weight	<ul style="list-style-type: none"> • Small Enclosure – < 1.9kg (model dependant) • Large Enclosure – < 4kg (model dependant)
Environmental	<ul style="list-style-type: none"> • Ingress protection – Enclosure IP65, Socket IP54 • Impact protection – IK08 • Operating temperature – -25°C to +60°C • Operating humidity – 5% to 95%
Materials	Enclosure – Polycarbonate (UV Stabilised)
Unit Colour	 Light grey
Certifications & Compliances	<ul style="list-style-type: none"> • Wiring Regulations (where applicable) – 18th Edition BS7671:2018+A1:2020 • Safety Compliance (LVD) – 2014/35/EU, SI 2016/1101 • Environmental Protection – BS EN 60529:1992+A2:2013 • Enclosure – EN 60670-1, EN 60670-22 • Cables (where applicable) – BS 6004 • Flame Retardance – IEC 60695-2-11:2014 • Impact Rating – BS EN 62262:2002+A1:2021 • Metering (where applicable) – EN50470-1, EN50470-3, MID B+D Certified, 2014/32/EU, SI 2016/1153 • RoHS – 2011/65/EU, SI 2012/3032 • REACH – 1907/2006 • Certification Markings – CE & UKCA
Warranty	12 Months



Options & accessories

Product Code	Item Description
LSAF0060	1350mm galvanised steel post to suit small & large hook-up connection unit enclosures
ACEQ0030	C6A 30mA 1P+N 2MOD Type A (6KA) RCBO
ACEQ0070	C10A 30mA 1P+N 2MOD Type A (6KA) RCBO
ACEQ0110	C16A 30mA 1P+N 2MOD Type A (6KA) RCBO
ACEQ0160	C32A 30mA 1P+N 2MOD Type A (6KA) RCBO
ACLG0050	Photocell kit to control park lighting
ACEU0160	63A 1Phase Class 1 MID smartcard meter
ACEU0170	Blank reusable smartcard (printing/branding available)
LSAF0180	Smartcard meter system software and reader/writer



ACEU0160

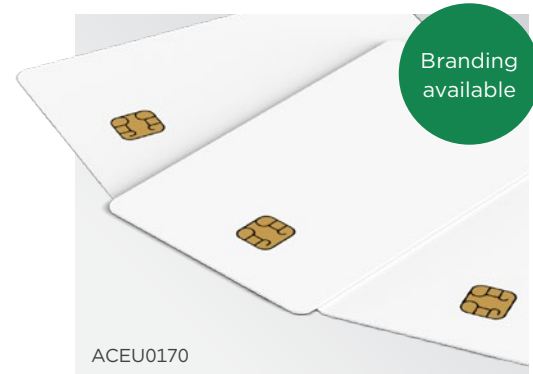

ACEU0170



LSAF0060



LSAF0180



ACLG0050

Smartcard metering & management



Rolec's smartcard metering is the ideal solution to efficiently control and manage a park's electric supplies. The smartcard meter includes a built-in electrical contactor that automatically switches the electricity supply on/off as credit becomes available or expires. Visitors pay upfront for their electricity consumption and any unused credit on the meter can be transferred back to the smartcard and returned to the office computer for a refund.

The smartcard meter system is an available option for the entire range of hook-up solutions and is perfect for caravan/holiday parks and similar locations that do not have the desire or capacity to install data cables or a networked management system.



- Pre-paid smartcard operated
- Class 1 accurate smartcard meter with digital display
- MID compliant
- Re-usable waterproof smartcards
- Easy to operate software
- USB card reader/writer
- Secure tariff management
- Audible & visual low credit warning
- Unused credit can be returned to the smartcard
- Smartcards are unique to each sites computer software



THIS DOCUMENT CONTAINS INFORMATION THAT IS SUBJECT TO CHANGE WITHOUT NOTICE.

The latest version of this publication can be downloaded at <https://www.rolecserv.com/downloads-caravan-hook-ups>

Illustrations of the product and user interface are for marketing purposes only.

Brand names, logos and trademarks used herein remain the property of their respective owners. This listing of any firm or their logos is not intended to imply any endorsement or direct affiliation with Rolec Services Ltd. and is purely to demonstrate branding opportunities.

© 2025 by Rolec Services Ltd. All rights reserved.
LSDCD-V01-R1 Direct Connection Units Data Sheet



Designed
& Stocked
in the UK

ROLEC

t: 01205 724754

e: enquiries@rolecserv.co.uk

www.rolecserv.com

