

MARINA MEGAMASTER

INSTALLATION & OPERATION MANUAL



ROLEC
Marina Services

Installation and Operation Manual - MSDSM-01-V01-R2
July 2022

Amendments

| Amendment Number | Details | Date |
|------------------|--|------------|
| Ver 1 Rev 0 | New Document. | March 2021 |
| Ver 1 Rev 1 | Amended Unpacking Information | April 2021 |
| Ver 1 Rev 2 | Addition of maintenance information for water systems | July 2021 |
| Ver 1 Rev 3 | Addition of safety circuit information for 600Amp direct connection units. | July 2022 |
| | | |
| | | |
| | | |

| | | |
|---|--|---|
| Product: | MegaMaster Distribution Unit Pedestal |  |
| Applicable Models: | 005, 006, 007 and derivatives | |
| Document Type: | Installation and End User Manual | |
| Document Code: | MMDUM-01-V01-R3 | |
| Language: | UK English (Original) | |
| Date Published: | July 2021 | |
| <p>Rolec Services Ltd are the publishers of this document and own the rights to use the text, images and all technical content contained within. Content supplied by third parties / partner organisations remains the property of that organisation and is used by agreement with the supplier.</p> <p>Rolec Services Ltd exercise care to ensure content is as accurate as possible at the time of publication. However, no guarantee of accuracy should be inferred.</p> | | |
| <p>Rolec Services Ltd, Ralphs Lane, Boston, Lincolnshire PE20 1QU. United Kingdom. +44 (0) 1205 724754 enquiries@rolecserv.co.uk</p> | | |

Contents

| | |
|----------------------------------|-----------|
| Safety | 4 |
| Safety Advice within this Manual | 5 |
| Product Overview | 5 |
| Product Specification | 6 |
| Physical Specification | 6 |
| Electrical Specification | 7 |
| Water Specification | 7 |
| Certifications and Compliances | 7 |
| Labelling | 8 |
| Options and Accessories | 8 |
| Installation | 9 |
| Before Installation | 9 |
| Schematics | 10 |
| 600 Amp Units | 13 |
| Ground Mounting Floor Plans | 14 |
| Unpacking | 15 |
| Typical Contents | 16 |
| Install the Unit | 16 |
| Commissioning | 19 |
| Operation | 19 |
| Maintenance | 20 |

Safety

This manual is specifically applicable to the MegaMaster Distribution Unit Pedestal and is provided as a guide to its installation and use.



WARNING: Electrical Power

Make sure electrical power is isolated BEFORE starting this procedure.

- Turn power OFF at the SOURCE.



WARNING: Potable Water

Equipment equipped with potable (drinking) water systems must be installed in accordance with the appropriate legislation in the region of installation.



IMPORTANT: Installers and End Users **must** read and **understand** the content of this manual before installation/use.

Installation must **only** be performed by someone who is properly qualified and competent to do so in accordance with the current legislation in force in the geographical location of the installation.

- If the advice in this manual is not understood, contact Rolec for further advice and/or training BEFORE attempting installation/operation of the equipment.
- Rolec Services Ltd cannot accept any responsibility for improper installation or any problems arising from improper installation.

NOTE: Damage to the equipment, connected systems or to property caused by improper installation/use are the responsibility of the installer/user.

- The information provided in this manual must ONLY be used with the model(s) listed on page 2 of this manual.
- The information provided in this manual must NOT be used with any other product.
- The content of this manual may be updated by the manufacturer as required.
- Do NOT use the equipment for anything other than its intended purpose.
- Do NOT modify the equipment unless specifically instructed to do so by the manufacturer.
- Do NOT attempt to repair the equipment unless specifically instructed to do so by the manufacturer.
- Damage to the product may render it unsafe. The product must be electrically isolated and NOT used until appropriate remedial action has been performed.

Safety Advice within this Manual

Rolec manuals use a system of warnings, cautions and notes.

- **WARNINGS** concern the safety of installers/end user and will be given before the detail/instructions in the manual.
- **CAUTIONS** concern the potential for damage to the equipment and will be given before the detail/instructions in the manual.
- **NOTES** are given to provide additional information and/or highlight information of importance. They will be given either before or after the detail/instructions as appropriate and may use different wording (such as IMPORTANT) where emphasis is required.

Warnings, Cautions and Notes may be repeated several times as appropriate and may be preceded by a hazard symbol.

Product Overview

MegaMaster is a heavy-duty pedestal unit designed specifically to provide services to large vessels such as super-yachts. Each MegaMaster is custom built from a library of components to meet the specific needs of the end user.

Depending on the requirements, one of three sizes of enclosure (models **005**, **006** and **007**) may be used, around which the bespoke pedestal is built.

NOTE: The bespoke nature of each unit means this manual cannot cover every model derivative. In the majority of cases, components used in different models will have similar methods of operation even if specifications such as the power rating are different.

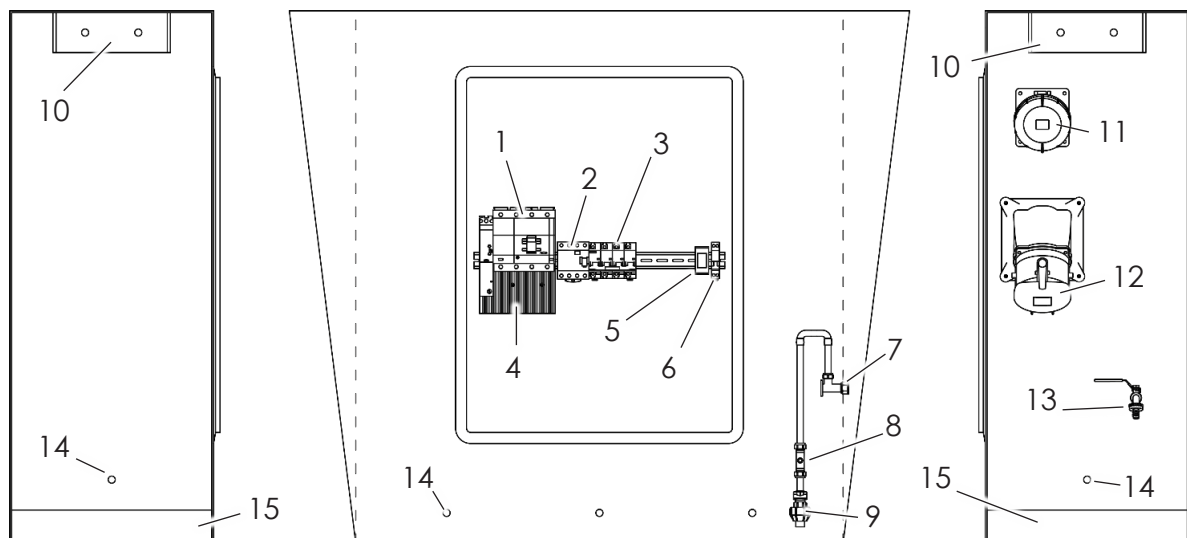

Figure 1 Typical Arrangement

- | | | |
|---------------|----------------------------|--|
| 1. MCCB | 6. MCB | 11. 125A 3-phase IP67 Socket |
| 2. RCD | 7. 1/2" Back Plate Elbow | 12. 250A 3-phase Marechal Socket |
| 3. MCB | 8. Non-return Valve | 13. 1/2" 1/4 Turn Stainless Steel Lockable Tap |
| 4. VIGI | 9. 1/2" Insert and Adapter | 14. Low level LED Lighting |
| 5. LED Driver | 10. LED Lighting | 15. Kick Board |

Product Specification

Physical Specification

| | |
|----------------------|--|
| Materials | Aluminium Powder coated outer casing GRP or Stainless-Steel internal panel options |
| Mass | Up to 300kg – depending on installed options |
| Environmental | <ul style="list-style-type: none"> • -30°C to +60°C operating temperature range • IP67 Enclosure weather resistance • IP44 and/or IP67 Socket weather resistance • IK10 Impact protection (enclosure) • Corrosion resistant/salt mist tested panels |

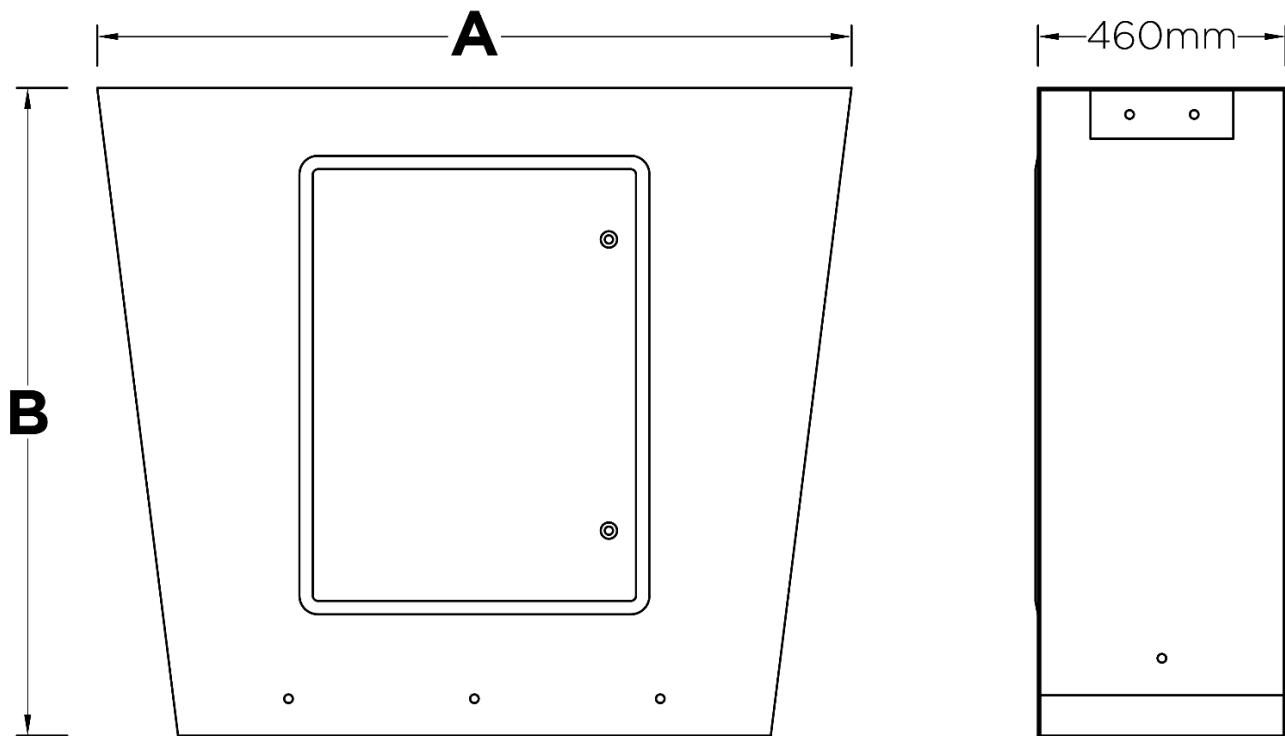

Figure 2 Generic Pedestal Dimensions

- 005:** A: 1200mm B: 750mm (Door: 650mm x 515mm)
006: A: 1400mm B: 1200mm (Door: 600mm x 800mm)
007: A: 1800mm B: 1400mm (Door: 800mm x 1010mm)

NOTES:

1. Dimensions **A** and **B** depend on the model selected.
2. Physical shape may vary from that shown above, depending on the customer's specification.

Electrical Specification

| | |
|--|--|
| Sockets | 16 Amp up to 400 Amp as per customer requirements. Direct Connections for 400 and 630 Amps. |
| Overload & Fault Current Protection | MCB/RCD or RCBO IEC 60898-1/IEC 60947-1/IEC 61009-1. |
| Lighting | LED Lighting 4x1 Watt or 9x1 Watt as per requirements. |

Water Specification

| | |
|--------------|--|
| Taps | 1/2", 3/4", 1" and 2" Taps as per customer requirements. |
| Input | MDPE Coupler. |
| Grade | Brass (UK), Stainless Steel (International). |

Certifications and Compliances

This product has been designed and is built in accordance with the following standards and legislation:

| | |
|----------------------------------|--|
| Wiring Regulations | BS 7671:2018/A1:2020 |
| Low Voltage Directive | 2014/35/EU |
| Switchgear | BS EN 61439-2:2011, BS EN 61439-5:2015 |
| Electromagnetic Directive | 2014/30/EU |
| EMC Directive | 2014/30/EU |
| Electrical Enclosure | <ul style="list-style-type: none"> Impact Protection IK10 (EN62262) IEC 61439-1, IEC 61439-2, IEC 60670-1, IEC 60670-24, IEC 62208 |
| Sockets | BS EN 60309-1, BS EN 60309-2 |
| Environmental Protection | IP Weather resistance BS EN 60529:1992+A2:2013 |
| Cable | BS6004 |
| RoHS | 2011/65/EU |
| REACH | 1907/2006 |



Labelling

Users must observe the information given on labels to ensure safe use of the product.



Figure 3 Typical Product Label





Figure 4 Power Warning Labels as Appropriate

NOTE: Sockets are individually labeled with their power rating as appropriate.

Options and Accessories

- Berthmaster remote management.
- Panel/Shell colours and materials.
- Branding vinyls.
- Electric and water metering.
- Switching and control.
- Air, TV telephone and data outlets.
- LED colours.
- Buss bar arrangements.
- Direct connections for 1000 Amps and 2000 Amps.

Installation

| | |
|--|--|
|  | <p>WARNING: Electrical Power Make sure electrical power is isolated BEFORE starting this procedure.</p> <ul style="list-style-type: none"> • Turn power OFF at the SOURCE. |
|  | <p>WARNING: Potable Water Equipment equipped with potable (drinking) water systems must be installed in accordance with the appropriate legislation in the region of installation.</p> |
|  | <p>IMPORTANT: Installers and End Users must read and understand the content of this manual before installation/use.</p> |
| <p>Installation must only be performed by someone who is properly qualified and competent to do so in accordance with the current legislation in force in the geographical location of the installation.</p> <ul style="list-style-type: none"> • If the advice in this manual is not understood, contact Rolec for further advice and/or training BEFORE attempting installation/operation of the equipment. • Rolec Services Ltd cannot accept any responsibility for improper installation or any problems arising from improper installation. | |
| <p>NOTE: Damage to the equipment, connected systems or to property caused by improper installation/use are the responsibility of the installer/user.</p> | |

Before Installation

1. Establish a suitable site location for the unit that is both secure and environmentally safe.
 - Before moving the unit to the site, make sure the location can support the weight of the unit and any transportation or lifting equipment that may be required.
2. Make sure the location meets current legislation (if applicable).
3. Make sure there is a suitable mains power supply available at the installation site.
4. Make sure there is a suitable water supply available at the installation site (if required).
 - If possible, pipework should be flushed to remove any debris or stale water before connecting to the pedestal.
5. Make sure any other required services such as TV, internet, etc. is available at the installation site.
6. Prepare the installation site, ready to receive the unit. The site must be flat and must enable the unit to be bolted down without twisting. Refer to the Ground Mounting Floor Plans on page 14 if required
7. Obtain suitable lifting equipment to lift and position the unit.

Schematics

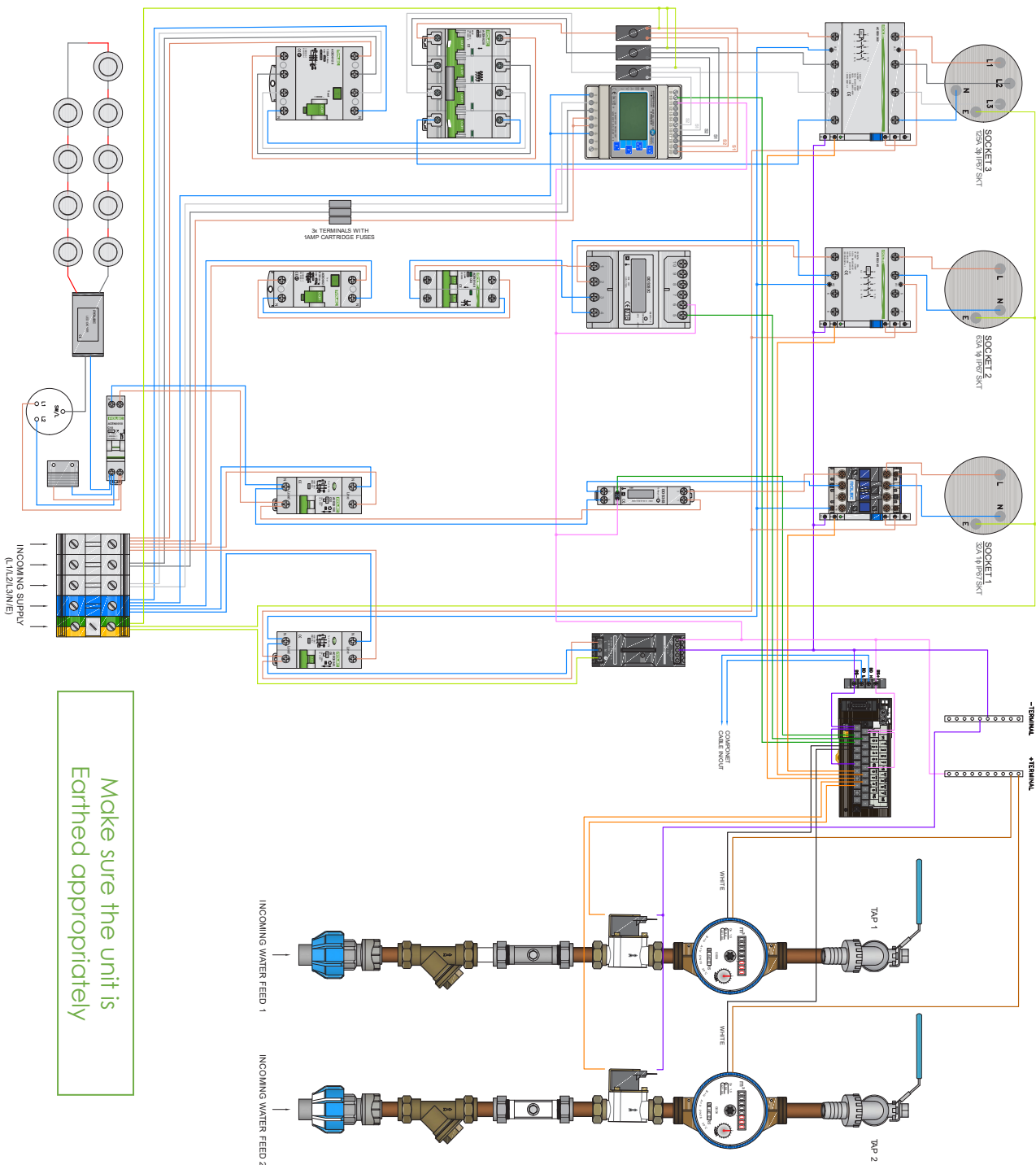

Figure 5 Example MegaMaster (BerthMaster) Wiring Schematic

NOTE: This schematic shows European wiring colours. Schematics with appropriate unit-specific and region-specific wiring are available on request.

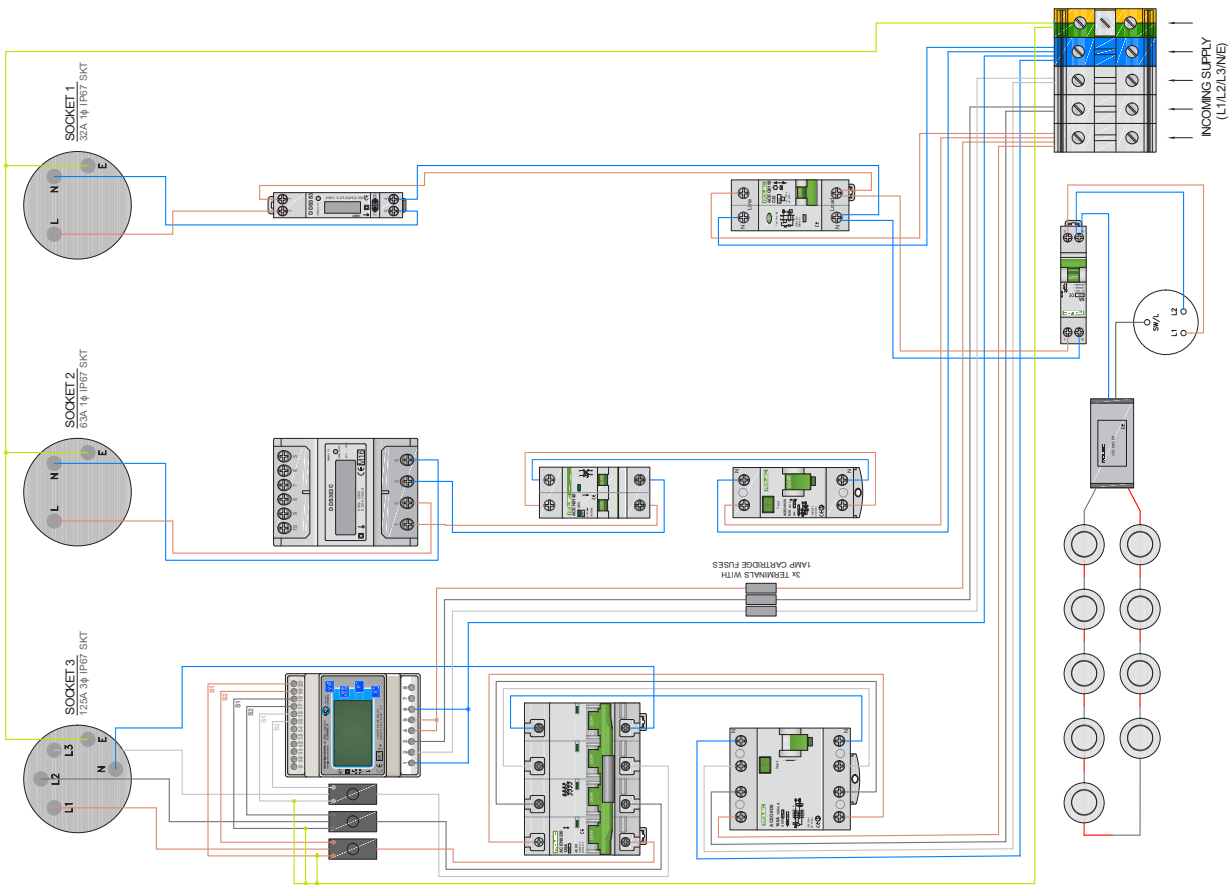
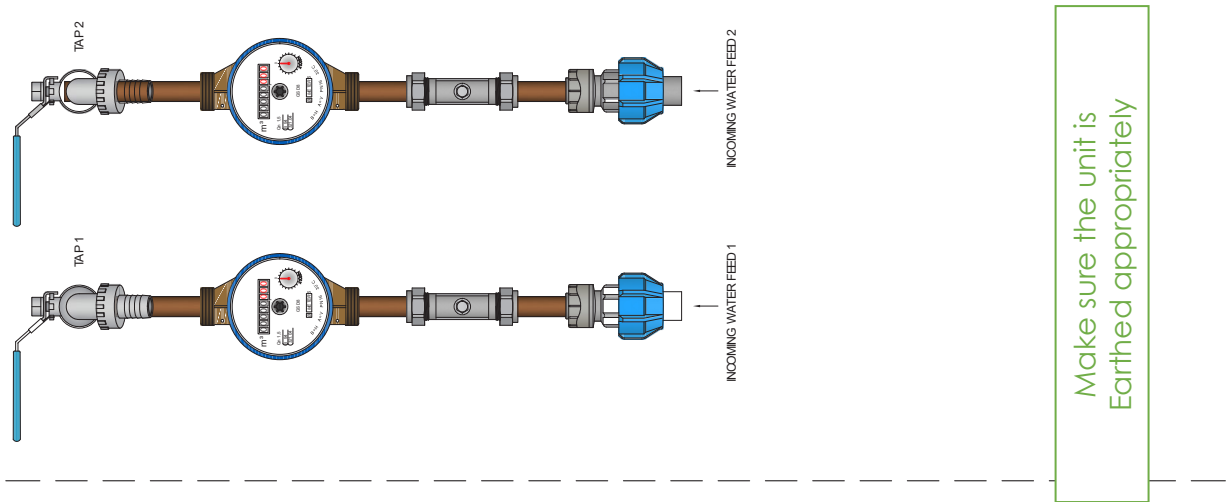

Figure 6 Example MegaMaster (Free-to-Use) Wiring Schematic

NOTE: This schematic shows European wiring colours. Schematics with appropriate unit-specific and region-specific wiring are available on request.

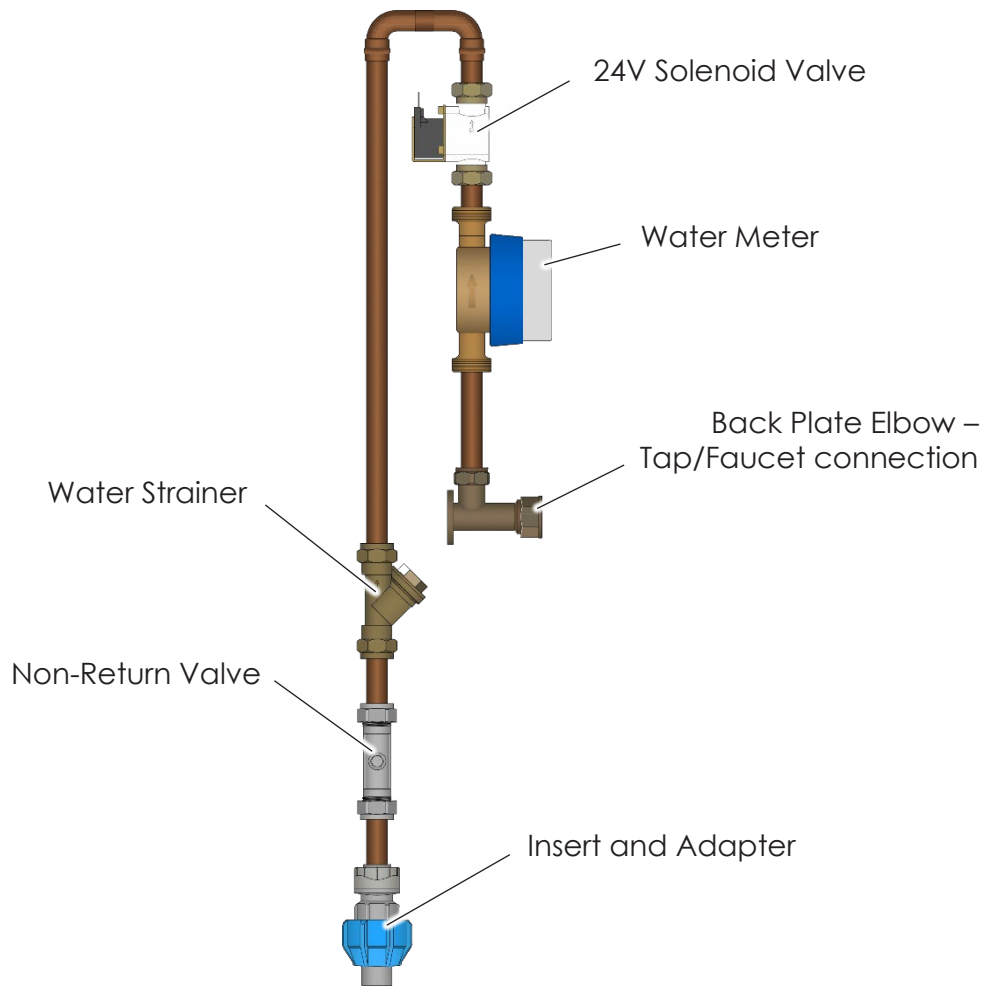

Figure 7 Typical Pipe Arrangement

600 Amp Units

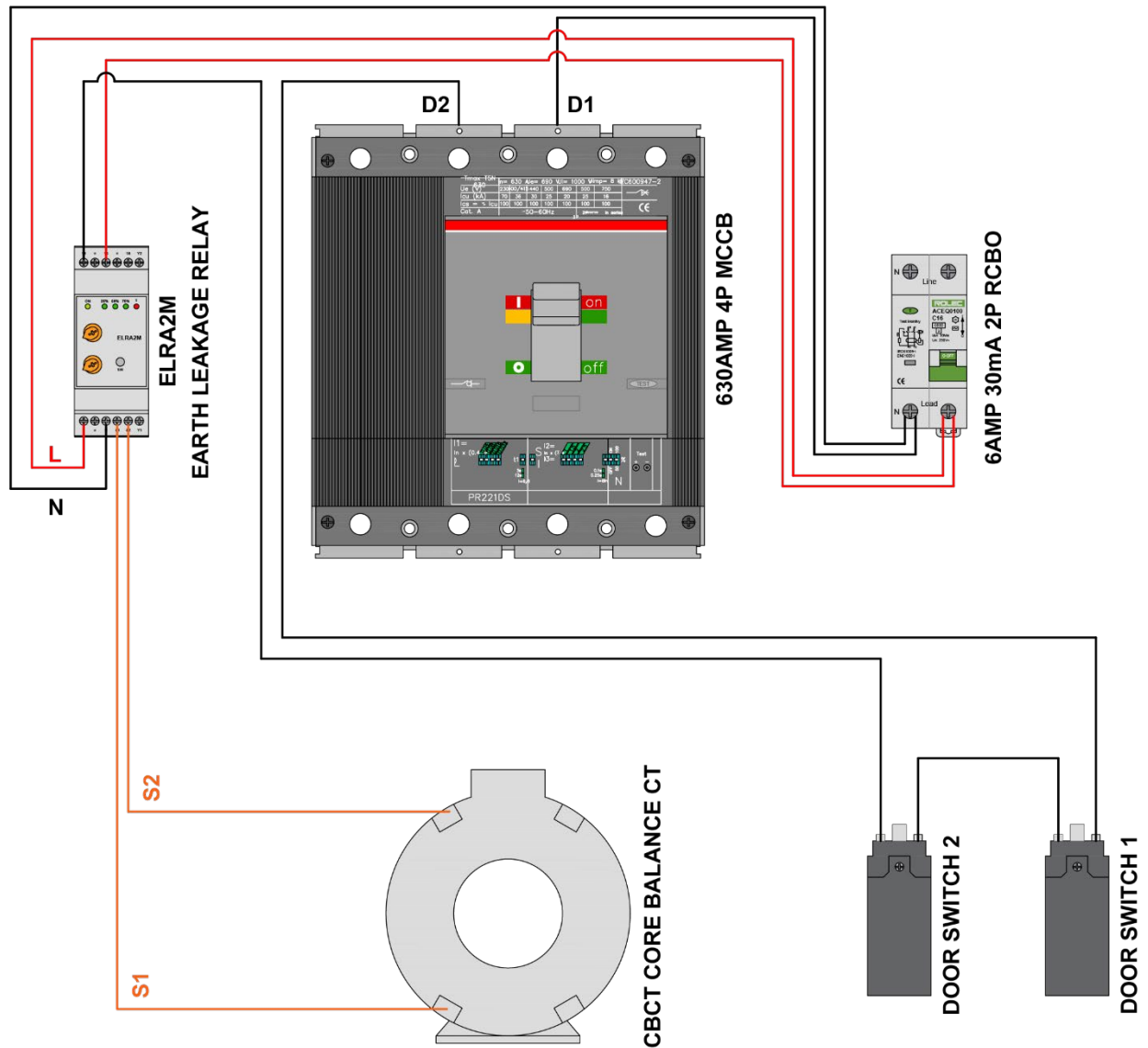

Figure 8 Safety Circuit for 600Amp Units

Products with higher power outputs have a safety system that removes power when the cabinet housing the connections is opened.

Before power is allowed to flow, microswitches on the cabinet must both be correctly in place when the cabinet is closed.

In addition, a Current Transformer (CT) is used to detect Earth Leakage. If a fault is detected, power to the unit will be removed by the Earth Leakage Relay.

The power cable **must** pass through the CT before it is connected to the unit.

Ground Mounting Floor Plans

Refer to the appropriate ground mounting template to prepare the site for the unit.

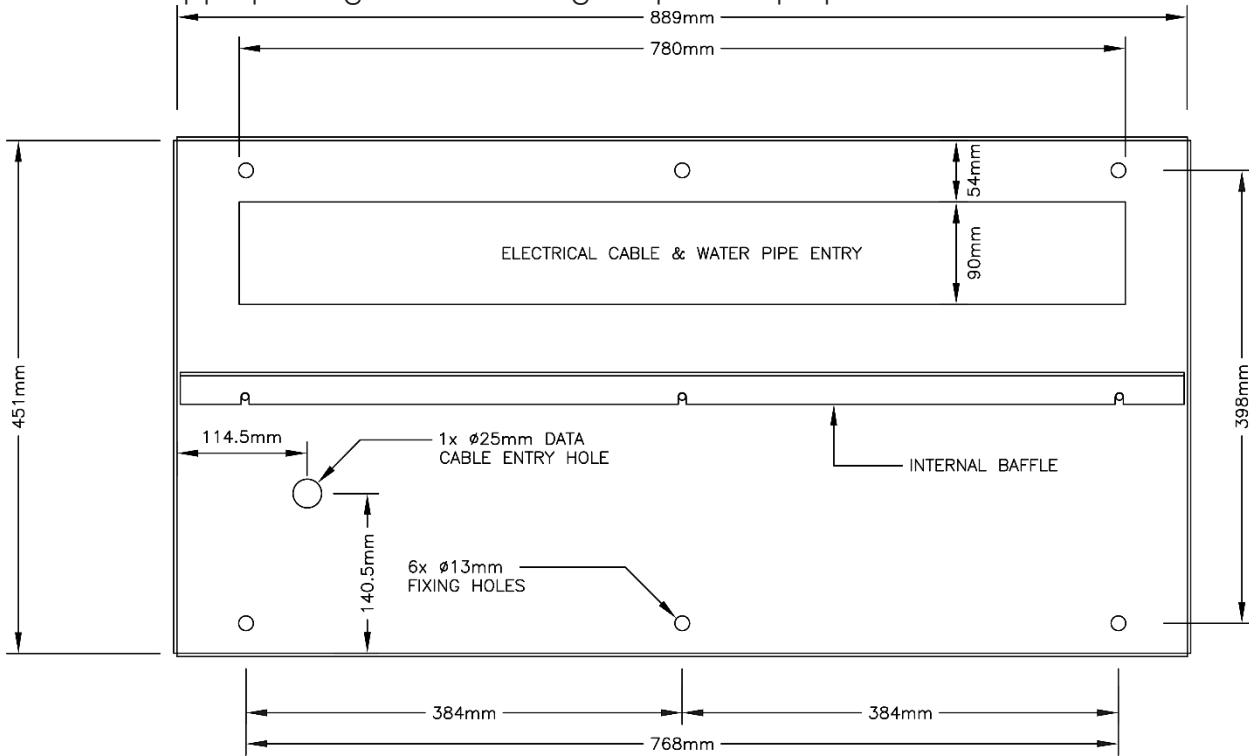

Figure 9 Floor Plan 005 Model

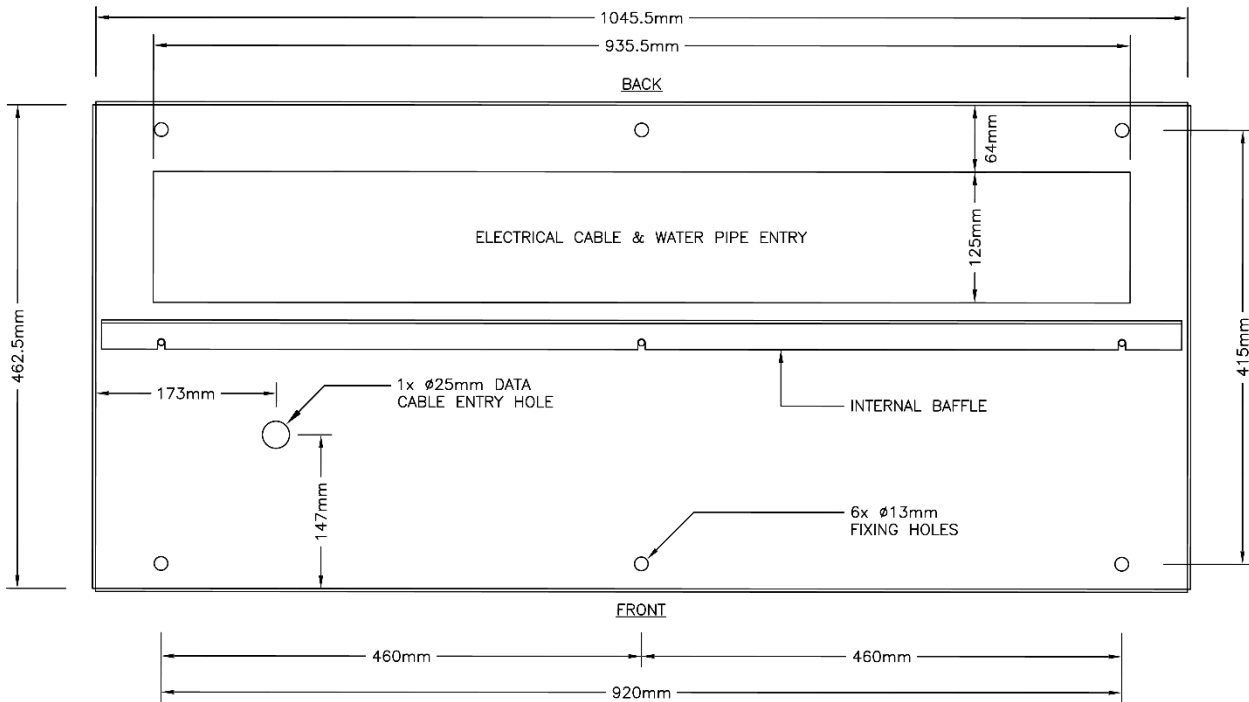

Figure 10 Floor Plan 006 Model

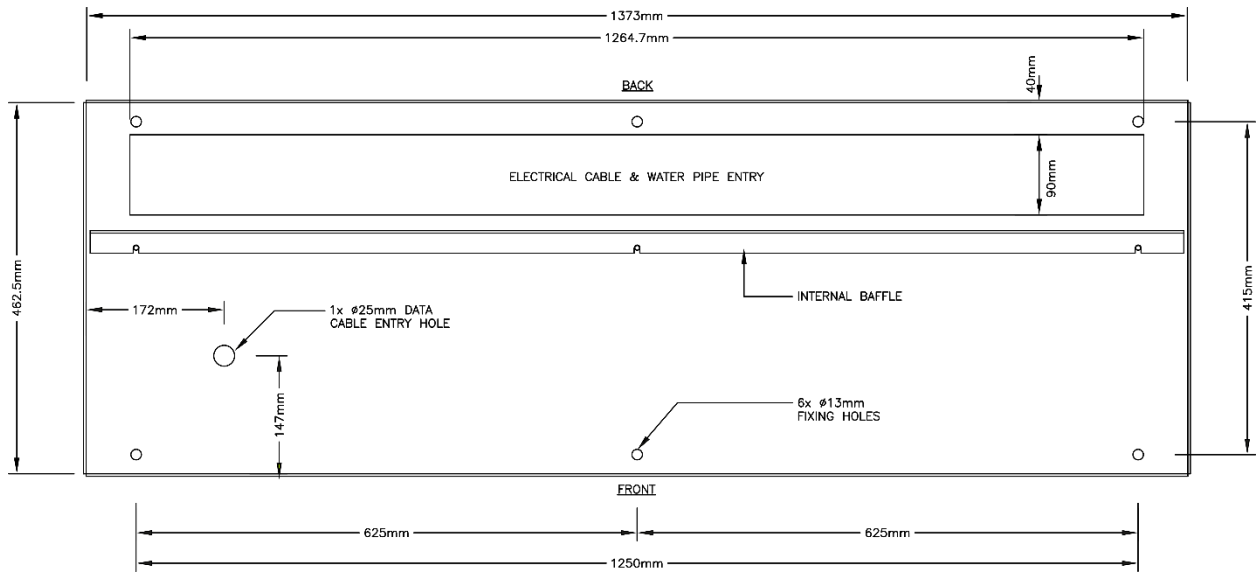

Figure 11 Floor Plan 007 Model

Unpacking

The content of the package depends on the model ordered and any options or accessories.

IMPORTANT: Make sure all packaging is disposed of responsibly and in accordance with the current regulations in your region.

Make sure the pedestal is NOT covered and all plastic packaging has been removed. Even in temperate climates, plastic packaging can cause localised heating of the pedestal that may result in temporary or permanent component failures.

1. Make sure that the unit and any accessories have not been damaged in transit.

NOTE: Items damaged in transit must first be reported to the courier and then to the supplier.

Where possible, photographic evidence of package and/or unit damage should be provided.

2. Make sure the unit model is correct and matches the order.

NOTE: Incorrect or damaged units must NOT be installed. Contact your supplier to discuss rectification.



WARNING: Heavy Load

MegaMaster can weigh up to 120 kg. Take care when lifting or moving the unit.

3. If possible, position the delivery pallet, close to the installation site.

- Before moving the unit to the site, make sure the location can support the weight of the unit and any transportation or lifting equipment that may be used.

- The installation site should be flat and level.
4. Remove any outer packaging.
 5. Carefully release any securing straps holding the unit on the pallet.
 - Be aware the unit may move when the straps are released.
 6. Using appropriate lifting methods, carefully remove the unit from the pallet.

Typical Contents

- MegaMaster Pedestal.
- Rubber Splash Mat.
- External Water Tap(s)/Faucet(s) (optional - enclosed loose in the packaging).
- Installation and Operators Manual.

Install the Unit

**WARNING: Electrical Power**

Make sure electrical power is isolated BEFORE starting this procedure.

- Turn power OFF at SOURCE.

NOTE: All electrical work must be performed in accordance with the current Electrical Wiring Regulations.

1. Remove and retain the fixings that secure the:
 - front and rear panels.
 - lid panel.
2. Remove the front, rear lid panels.
3. Lay out the Splash Mat on a flat surface. The MegaMaster unit will be used as a guide to mark the cable entry, pipe entry and bolt down positions.
4. Carefully lift the pedestal then lower it onto the splash mat.
 - Make sure the mat and unit are correctly aligned
 - Use the apertures in the base of the unit as a guide and mark the mat at the cable entry, pipe entry and bolt down positions.
5. Carefully lift the pedestal from the splash mat.
6. Use a sharp knife to cut 'X' shaped slits through the splash mat at the marked positions.
7. Place the splash mat onto the mounting location.
 - Feed the cable(s) and pipe through the splash mat.
 - Make sure the mat is correctly aligned with the mounting location, cable and pipe positions and the bolt down positions.
 - If required, adjust the size/location of the slits in the splash mat to achieve the best fit.

8. Use appropriate lifting gear to carefully lift the pedestal then lower it onto its mounting location.
9. Secure the unit to the ground with the correct type and size of fasteners for the location.
10. Assist the cable(s) pipe(s) and any other services to enter the unit through the appropriate locations within the base.
11. Remove the cover from the unit's terminal box.
12. Route the cable(s) to the appropriate length to be able to connect to the unit.

NOTE: All electrical and plumbing work must be performed by an appropriately qualified engineer(s) in accordance with the current regulations.

13. Secure the incoming cable(s) to the gland plate or cable clamp(s).
14. Terminate the supply cable in the appropriate manner and connect to the pedestal as per the appropriate schematic.

NOTE: If a high-powered unit (600 Amps or more) is being installed, additional safety devices are pre-fitted to the unit. The power supply cable must pass through the Current Transformer before being connected to the unit. See page 13, 600 Amp Units.

15. Make sure cable connections are secure and have not become loose or damaged in transit or during installation.
16. Refit the cover on the terminal box.
17. Allow water to flow from the water pipe supply pipe to remove any debris or stale water before connecting to the pedestal.
18. Connect the water supply to the pedestal in accordance with the current, legislation.
19. Temporarily attach the tap(s)/faucet.

CAUTION: Equipment Damage

If an external water tap/faucet is to be installed, do NOT attempt to force the connection to be tight and vertically aligned. The tap and/or water system will be damaged. Refer to step 20 for further details.

20. If an external water tap/faucet is to be installed, make sure to apply sufficient thread sealing tape to the tap threads to ensure the connection will become vertically aligned and tight **BEFORE** reaching the end of the threads.
 - Test fit the tap (without sealing tape) to determine the point at which the fitting can no longer turn (the end of the threads).
 - Remove the tap and apply sealing tape to the threads of the tap connection.
 - Fit the tap and ensure it becomes tight and vertically aligned before reaching the end of the threads.
 - If required, repeat these steps to either add or remove sealing tape until the correct fitting and alignment is achieved.

21. Turn the water supply ON and test the system for leaks and security of connection.

WARNING: Electrical Power

Do NOT apply electrical power to the unit until all water connections are secure and leak free.

- Make sure electrical components are dry before power is applied.

22. Make sure ALL debris is removed from the enclosure and that no debris is present on any of the components.

IMPORTANT NOTE:

- It is the responsibility of the installing engineer to satisfy themselves that all cable terminations throughout this product are secure and tight and have not become loose, strained or disconnected during transit and/or installation.
- It is the responsibility of the installing engineer to satisfy themselves, that the water connection has been performed in accordance with the current, appropriate legislation.

23. Turn the water supply OFF and remove the tap(s)/faucet.

24. Refit the front, rear and lid panels.

- Secure the panels with the fasteners removed at the start of the procedure.

25. Refit the tap(s)/faucet then turn the water supply ON.

WARNING: Electrical Power

Make sure it is safe to apply electrical power to the unit.

26. Open the electrical cabinet in the side of the unit.

27. Switch ON the internal switchgear for the power and illumination (if fitted).

Commissioning

Before handing over to the customer:

| | |
|-------------------|--|
| Switchgear | Test the switchgear protecting the socket(s) in accordance with the regulations. |
| Socket | Test the polarity of each socket in accordance with the regulations. |
| Meters | If fitted, make sure electricity meters are functioning correctly. |
| LED Lamp | <p>If fitted, the pedestal may incorporate an amenity illumination lamp which activates in response to changing light levels.</p> <ol style="list-style-type: none"> 1. Cover the light sensor, the lamp should illuminate. 2. Uncover the light sensor and the lamp should switch OFF. <p>NOTE: To prevent flickering in frequently changing light conditions the lamp has a built-in delay before it switches on / off.</p> |
| Water | <ol style="list-style-type: none"> 1. If fitted, turn on the tap(s) and allow water to flow to remove any stale water in the system or water supply pipes. 2. Measure the volume of water flowing against the figures on the meter. 3. Perform a visual check that water flow/pressure appears sufficient. <p>NOTE: Debris in the water may cause water meters to fail or to provide incorrect readings.</p> |
| Inspect | <ol style="list-style-type: none"> 1. Make sure you are satisfied that the installation is complete and is in a safe condition. 2. Make sure all information labels are present, undamaged and visible. 3. Clean the pedestal ready for hand over to remove handling and installation marks. |
| Handover | <p>Make sure the pedestal is NOT covered and all plastic packaging has been removed. Even in temperate climates, plastic packaging can cause localised heating of the pedestal that may result in temporary or permanent component failures.</p> <p>Make sure this manual is given to the customer along with copies of any installation paperwork.</p> |

Operation

Operators who have chosen the BerthMaster option should refer to the BerthMaster Operation Manual and the BerthMaster Management Portal Operation Manual as appropriate.

Maintenance

NOTE: In the event of a hardware issue, always contact your installer first.

- Damage caused to the equipment by misuse, lack of maintenance, inappropriate maintenance or modification is not covered by the manufacturer warranty.



WARNING: Electrical Power

This pedestal enclosure does NOT need to be opened for routine maintenance tasks.

1. Regularly clean the external surfaces of the equipment by wiping with a damp cloth.

CAUTION: Equipment Damage

To avoid damage to the surface finish, and/or internal components do NOT use:

- Abrasive materials.
- Mineral or petroleum solvents / degreasers.
- Hose pipes, Jet washers or Steam cleaners.

Cleaning using these methods will invalidate the warranty.

2. Regularly, visually inspect the exterior of the equipment for damage.
 - If damage affects safety, isolate the equipment and prevent its use until appropriate repairs have been completed.
3. Water systems must be allowed to flow on a regular basis to reduce the opportunity for calcification or other accumulations of water born solids which may cause water meter inaccuracy or failure.
 - If a water system has not been used for several weeks, the system should be allowed to flow, and meter accuracy should be assessed before relying on meter readings for billing.
 - Where deposits (scale) have formed within components, it should be removed with a proprietary de-scaling chemical suitable for use with food preparation equipment. Make sure to follow the manufacturer's instructions regarding the correct and safe use of the chemical(s).
4. Perform a functional test of the switchgear every six months by pressing the test button and making sure that the switchgear deactivates.
 - If the equipment fails the test, isolate the equipment and prevent its use until appropriate repairs have been completed.
 - On devices without a test button, move the switch between the ON/OFF/ON position a couple of time to check for correct operation.
5. The pedestal and switchgear should be routinely inspected by a qualified electrical engineer in accordance with the current legislation for the installation location.
 - The inspection periodicity may vary between regions.
 - If the equipment fails the test, isolate the equipment and prevent its use until appropriate repairs have been completed.

ROLEC

Marina Services

THE WORLD'S LEADING MARINA
SERVICES SPECIALIST



Head office contact:
t: +44 (0) 1205 724754
f: +44 (0) 1205 724876
rolec@rolecserv.co.uk

 @RolecMarina
www.rolecserv.com